



*Setting the Standard With the
World's Most Valued Grinders.*

MODEL 460 AUTOMATIC ROTARY BLADE GRINDER

This book consists of two manuals:

The OPERATORS MANUAL which contains all the information on operating and doing routine daily maintenance on this equipment.

The ASSEMBLY and SERVICE MANUAL which is used by the maintenance department to install the equipment and to do all maintenance except routine daily maintenance.

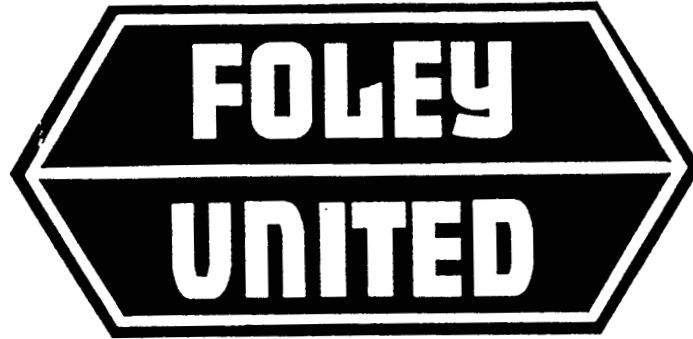

Setting the Standard With the World's Most Valued Grinders.

We are committed to:

Providing superior customer support, training, and service.

Manufacturing the highest quality products at an unequaled value.

Setting the industry standard by investing in technological product innovation.

Manufacturing products specifically designed to maintain original equipment manufacturers' specifications.

Interacting with and supporting all original equipment manufacturers.

MODEL 460 AUTOMATIC ROTARY BLADE GRINDER

OPERATORS MANUAL



WARNING

You must thoroughly read and understand this manual before operating the equipment, paying particular attention to the Warning & Safety instructions.

SAFETY INSTRUCTIONS



Safety Awareness Symbols are inserted into this manual to alert you to possible **Safety Hazards**. Whenever you see these symbols, follow their instructions.



The **Warning Symbol** identifies special instructions or procedures which, if not correctly followed, **could result in personal injury**.

The **Caution Symbol** identifies special instructions or procedures which, if not strictly observed, **could result in damage to or destruction of equipment**.

1. **KEEP GUARDS IN PLACE** and in working order.
2. **REMOVE WRENCHES AND OTHER TOOLS.**
3. **KEEP WORK AREA CLEAN.**
4. **DON'T USE IN DANGEROUS ENVIRONMENT.** Don't use Grinder in damp or wet locations. Machine is for indoor use only. Keep work area well lit.
5. **KEEP ALL VISITORS AWAY.** All visitors should be kept a safe distance from work area.
6. **MAKE WORK AREA CHILD-PROOF** with padlocks or master switches.
7. **DON'T FORCE THE GRINDER.** It will do the job better and safer if used as specified in this manual.
8. **USE THE RIGHT TOOL.** Don't force the Grinder or an attachment to do a job for which it was not designed.
9. **WEAR PROPER APPAREL.** Wear no loose clothing, gloves, neckties, or jewelry which may get caught in moving parts. Nonslip footwear is recommended. Wear protective hair covering to contain long hair.
10. **ALWAYS USE SAFETY GLASSES.**
11. **SECURE YOUR WORK.** Make certain that the rotary blade is securely fastened with the components provided before operating.
12. **DON'T OVERREACH.** Keep proper footing and balance at all times.
13. **MAINTAIN GRINDER WITH CARE.** Follow instructions in the Assembly and Service Manual for lubrication and preventive maintenance.
14. **DISCONNECT POWER BEFORE SERVICING.**
15. **REDUCE THE RISK OF UNINTENTIONAL STARTING.** Make sure all switches are OFF before plugging in the Grinder.
16. **USE RECOMMENDED ACCESSORIES.** Consult the manual for recommended accessories. Using improper accessories may cause risk of personal injury.
17. **CHECK DAMAGED PARTS.** A guard or other part that is damaged or will not perform its intended function should be properly repaired or replaced.
18. **KNOW YOUR EQUIPMENT.** Read this manual carefully. Learn its application and limitations as well as specific potential hazards.
19. **KEEP ALL SAFETY DECALS CLEAN AND LEGIBLE.** If safety decals become damaged or illegible for any reason, replace immediately. Refer to replacement parts illustrations in Service Manual for the proper location and part numbers of safety decals.
20. **DO NOT OPERATE THE GRINDER WHEN UNDER THE INFLUENCE OF DRUGS, ALCOHOL, OR MEDICATION.**

SAFETY INSTRUCTIONS



IMPROPER USE OF GRINDING WHEEL MAY CAUSE BREAKAGE AND SERIOUS INJURY.

Grinding is a safe operation if the few basic rules listed below are followed. These rules are based on material contained in the ANSI B7.1 Safety Code for "Use, Care and Protection of Abrasive Wheels". For your safety, we suggest you benefit from the experience of others and carefully follow these rules.

DO

1. **DO** always **HANDLE AND STORE** wheels in a **CAREFUL** manner.
2. **DO VISUALLY INSPECT** all wheels before mounting for possible damage.
3. **DO CHECK MACHINE SPEED** against the established maximum safe operating speed marked on wheel.
4. **DO CHECK MOUNTING FLANGES** for equal and correct diameter.
5. **DO USE MOUNTING BLOTTERS** when supplied with wheels.
6. **DO** be sure **WORK REST** is properly adjusted.
7. **DO** always **USE A SAFETY GUARD COVERING** at least one-half of the grinding wheel.
8. **DO** allow **NEWLY MOUNTED WHEELS** to run at operating speed, with guard in place, for at least one minute before grinding.
9. **DO** always **WEAR SAFETY GLASSES** or some type of eye protection when grinding.
10. **DO TURN OFF COOLANT** before stopping to avoid creating an out-of-balance condition.

DON'T

1. **DON'T** use a cracked wheel or one that **HAS BEEN DROPPED** or has become damaged.
2. **DON'T FORCE** a wheel onto the machine **OR ALTER** the size of the mounting hole. If wheel won't fit the machine, get one that will.
3. **DON'T** ever **EXCEED MAXIMUM OPERATING SPEED** established for the wheel.
4. **DON'T** use mounting flanges on which the bearing surfaces **ARE NOT CLEAN, FLAT AND FREE OF BURRS.**
5. **DON'T TIGHTEN** the mounting nut **EXCESSIVELY.**
6. **DON'T** grind on the **SIDE OF THE WHEEL** (see Safety Code B7.2 for exception).
7. **DON'T** start the machine until the **WHEEL GUARD IS IN PLACE.**
8. **DON'T JAM** work into the wheel.
9. **DON'T STAND DIRECTLY IN FRONT** of a grinding wheel whenever a grinder is started.
10. **DON'T FORCE GRINDING** so that motor slows noticeably or work gets hot.



AVOID INHALATION OF DUST generated by grinding and cutting operations. Exposure to dust may cause respiratory ailments. Use approved NIOSH or MSHA respirators, safety glasses or face shields, and protective clothing. Provide adequate ventilation to eliminate dust, or to maintain dust level below the Threshold Limit Value for nuisance dust as classified by OSHA.

SAFETY INSTRUCTIONS

This machine is intended for grinding the rotary blades from a rotary type mowing unit ONLY. Any use other than this may cause personal injury and void the warranty.



To assure the quality and safety of your machine and to maintain the warranty, you **MUST** use original equipment manufactures replacement parts and have any repair work done by a qualified professional.



ALL operators of this equipment must be thoroughly trained BEFORE operating the equipment.

Do not use compressed air to clean grinding dust from the machine. This dust can cause personal injury as well as damage to the grinder. Machine is for indoor use only. Do not power wash machine.

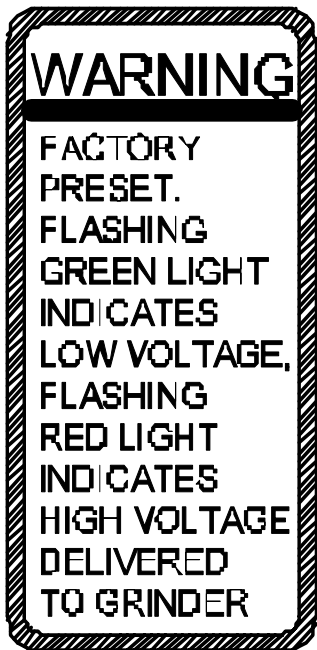

The grinder is equipped with a high/low voltage relay (LVR) which is factory preset at 100 VAC low voltage trip and 140 VAC high voltage trip. If the power supply line does not deliver a minimum of 100 VAC and a maximum of 140 VAC power under load, the relay will open and trip out the starter. If this occurs, your power supply line is inadequate and must be correct before proceeding further with the grinder.

A steady green light indicates - Power Up/ Fault cleared.

A steady red light indicates - Relay energized

A flashing red light indicates - Overvoltage trip

A flashing green light indicates - Undervoltage trip

CONTENTS

Safety Warnings	Page 4 - 7
Getting to Know your Grinder	Page 8 - 12
General Operating Instructions	Page 13 - 15
Operating Instructions	Page 16 - 23
Setup Chart	Page 24

SPECIFICATIONS

Electrical Requirements	115VAC 50/60 Hz, 15-amp circuit (230 VAC 50/60Hz, 8-amp circuit with transformer Model 4600951)
Net Weight	890 lbs [404 kg]
Shipping Weight	1080 lbs [490 kg]
Maximum Grinding Length	34 in. [86 cm]
Sound Level	Less than 75 DbA

DAILY MAINTENANCE

On a daily basis, clean the grinder by wiping all areas down.

On a daily basis, clean lower dust tray by vacuuming.

On a daily basis, inspect the grinder for loose fasteners or components and tighten.

Contact your company's Maintenance Department if damaged or defective parts are found.



DO NOT USE COMPRESSED AIR TO CLEAN GRINDING DUST FROM THE GRINDER.

SAFETY INSTRUCTIONS

PLEASE TAKE SPECIAL NOTE OF THE FOLLOWING WARNING DECALS LOCATED ON THE 460 ROTARY BLADE GRINDER.

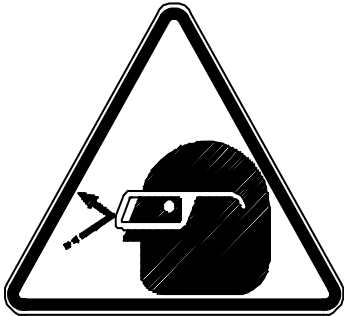

Symbol to wear safety glasses.



Symbol for caution relating to RPM of the motor and minimum safe rated RPM of the grinding wheel.



Symbol for keep visitors a safe distance away from grinder.

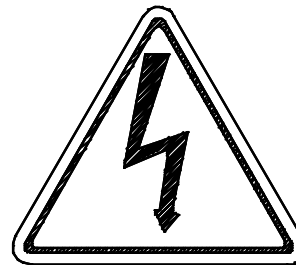

Symbol identifying a panel, cover, or area as having live electrical components within.



Symbols to disconnect power before servicing.



Symbol for sharp object which will cause serious injury.

GETTING TO KNOW YOUR GRINDER

FIG. 1 shows the major areas of the Grinder which will be referred to in the operating instructions in the remainder of this manual.

The next few pages show details of some of those areas and point out the various controls you will use when operating.

CONTROL BOX

The control box contains the electrical controls for the Grinder. START and STOP switches are located on the top control panel. See Page 9 for details.

GRINDING HEADS

The grinding heads consists of the grinding wheel, spark guard and the motor which drives the grinding wheel. See Page 10 for details.

DRIVE CARRIAGE AND VERTICAL ADJUSTER

The carriage and vertical grinding head adjuster provide a movable support for the grinding head. A infeed stepper motor (see Page 10 for details) adjusts the grinding wheel position in and out. A vertical adjuster and lock adjusts the grinding head position up and down. A grind angle position adjuster and lock adjusts the grind angle.

TRAVERSE MOTOR AND DRIVE BELT

A traverse drive belt and clamps traverse the carriages from side to side, to move the grinding wheel along the rotary blade. The belt is driven by a motor at the right end of the machine.

ROTARY BLADE SUPPORTS

A blade clamp cam system and a center cone support the rotary blade for grinding. See Page 11 for details.

PROXIMITY SWITCHES

Two movable proximity switches determine the left and right limits of carriage traverse. An LED on the switch lights when the switch actuator on the bottom of the carriage gets close to the head of the switch (touching the switch head with a steel object will trigger the switch). See Page 12 for details.

LOWER DUST TRAY

A large lower dust tray collects the grinding swarf for removal by separate shop vacuum.

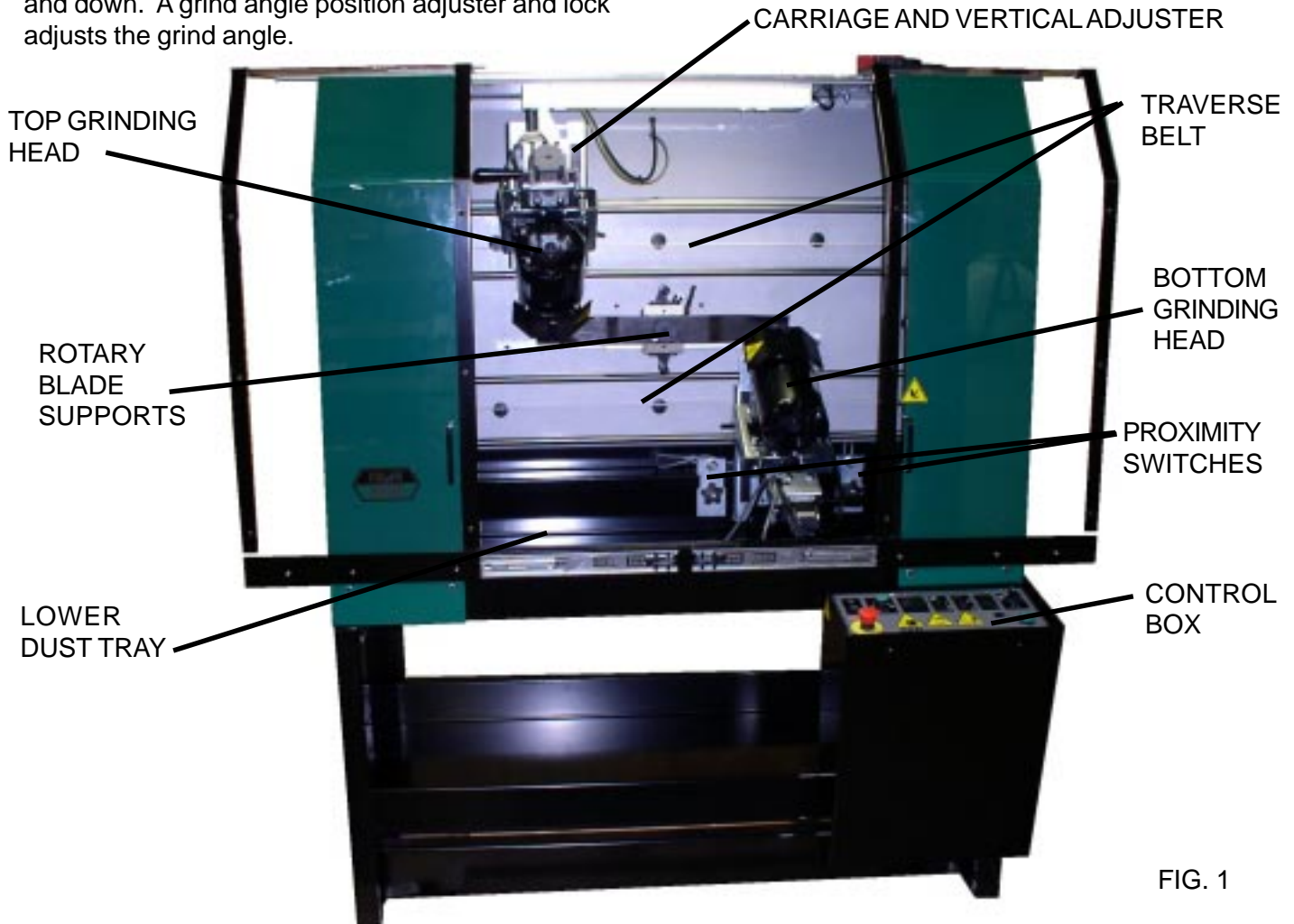

FIG. 1

GETTING TO KNOW YOUR GRINDER (Continued)

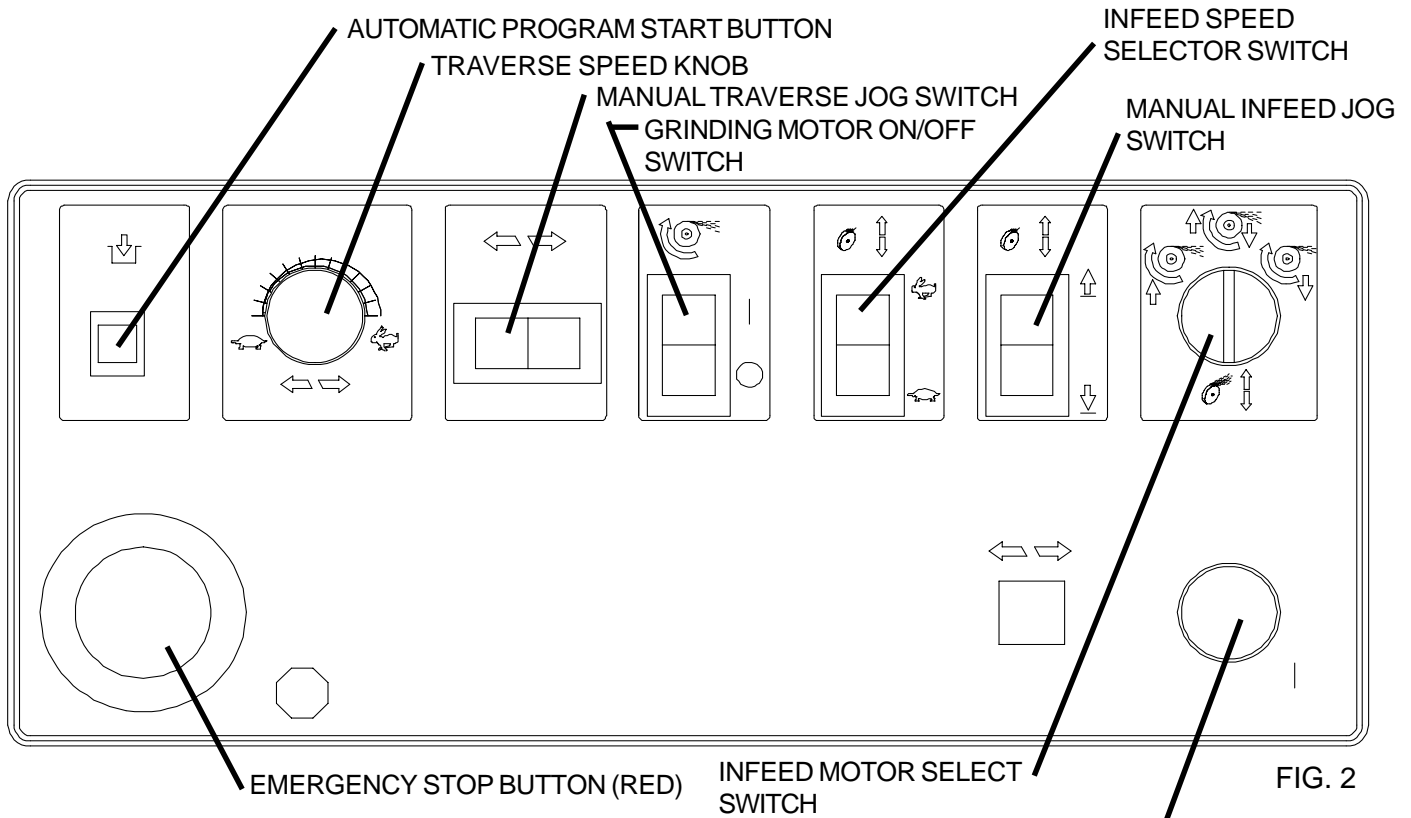

FIG. 2

CONTROL PANEL (FIG. 2)

TRAVERSE SPEED KNOB

Controls the travel speed of the carriage and grinding heads, from 0 - 35 feet [0 - 10.7 meters] per minute.

START BUTTON (Green)

Acts as a reset button after STOP has been pressed. The grinding motor switch must be in the off position or the start button will not reset.

EMERGENCY STOP BUTTON (Red)

Shuts down power to the Grinder.

NOTE: BUTTON MUST BE PULLED UP FOR START BUTTON TO ENGAGE.

MANUAL TRAVERSE JOG SWITCH

When pushed, controls the direction of the manual traverse of the two grinding head carriages.

GRINDING MOTOR ON/OFF SWITCH

Controls electrical power to the grinding head motors. This switch is tied into the door interlock. This switch will function only when the doors are closed.

AUTOMATIC PROGRAM START BUTTON

With the doors shut, pushing the button will start an automatic grind program. One push of the button will infeed .002" [.05 mm] and traverse the grinding head 5 times for .010 [.25 mm] total steel removal. Button can be push as many times as desired.

INFEED MOTOR SELECT SWITCH

START BUTTON (GREEN)

INFEED SPEED SELECTOR SWITCH

Controls the speed of infeed. Selectable to fast (Rabbit) or slow (Turtle)

MANUAL INFEED JOG SWITCH

When pushed, controls the direction of manual infeed.

INFEED MOTOR SELECT SWITCH

Control which grinding head infeeds, top, both or bottom.

The START and STOP buttons control the main power to the Grinder. To start the grinding operation: With Grinding Motors Switch OFF and the guard door closed, pull up on the stop button and press the START button.



FOR SAFETY, WHENEVER STOP IS PRESSED TO SHUT DOWN THE MACHINE, SHUT OFF GRINDING MOTORS SWITCH. YOU CAN THEN PRESS START TO START THE GRINDER.

GETTING TO KNOW YOUR GRINDER (Continued)

DRIVE CARRIAGE (FIG. 3)

Vertical Grinding Head Adjuster and Lock Pin

Moves the grinding head up and down. Position lock pin and lock handles lock adjustment in place.

Infeed Stepper Motor

Moves the grinding head infeed in and out.

Grind Angle Position Adjuster and Lock

Calibrated in 2 degree increments, so you can accurately move the grinding wheel to the angle required for the rotary blade.

GRINDING HEAD (FIG. 3)

Spark Guard Lock Knob

A two pronged knob holds the spark guard in position. Loosen it to slide the guard in or out to compensate for grinding wheel wear and to maintain clearance to other components and the rotary blade.

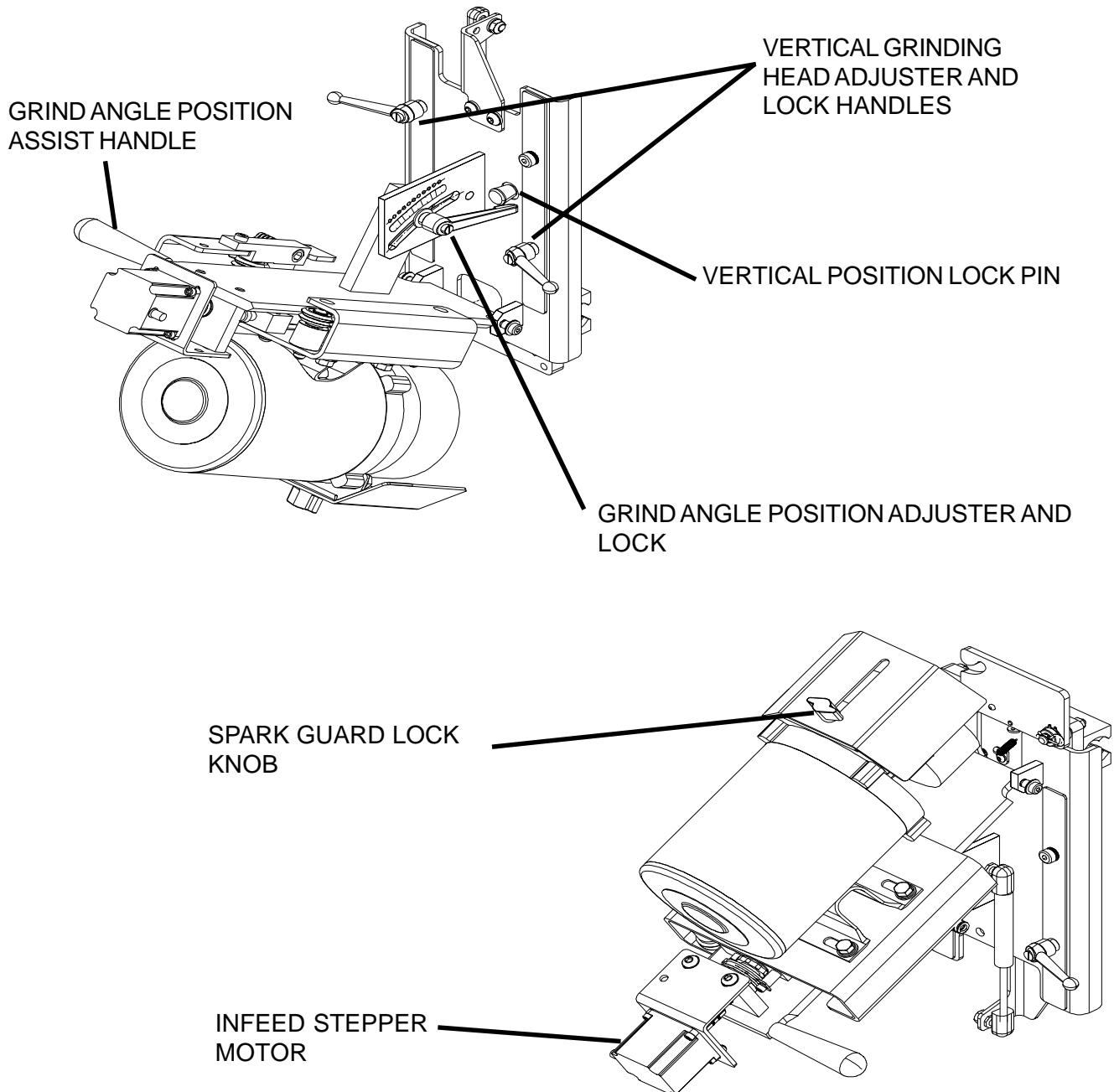

FIG. 3

GETTING TO KNOW YOUR GRINDER (Continued)

ROTARY BLADE CENTER SUPPORT ASSEMBLY:

See FIG. 4 and FIG. 5

BLADE CLAMP CAM SYSTEM

The blade clamp system consists of two Blade Clamp Blocks that are moved to the clamping position by a cam plate with two handles.

ANGULAR LOCK SYSTEM WITH ZERO POSITION PIN

The angular lock system consist of a Lock Clamp Plate with a locking adjustable handle and a spring plunger to establish the zero angle position.

BALANCE ALIGNMENT PIN

The balance alignment pin is a spring loaded plunger pin that locks in for grinding and locks out for balance checking.

RELIEF SLIDE BAR AND LOCK

The relief slide bar carries the relief release system on its end and is adjustable with its sliding function to set the relief start position as required for the rotary blade being ground. It has a lock knob to hold that position. The relief slid bar can be removed and loaded from the opposite end for rotary blades requiring grinding on the opposing side.

RELIEF RELEASE SYSTEM

The relief release system consists of spring loaded release bar that interacts with a cam plate to rotate the rotary blade during grinding to create a blend out radius at the inside of the grind.

BLADE RETAINING CONE

The blade retaining cone consists of a retaining cone with a quick release for fast installation and removal. The quick release has a lock slide pin.

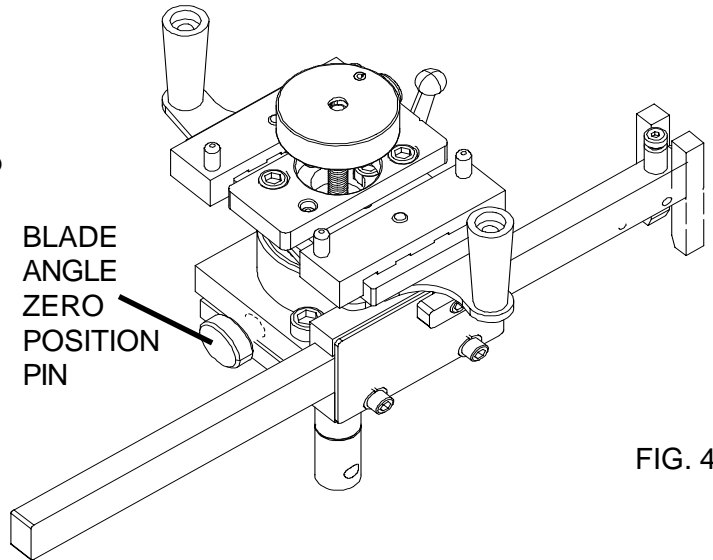

FIG. 4

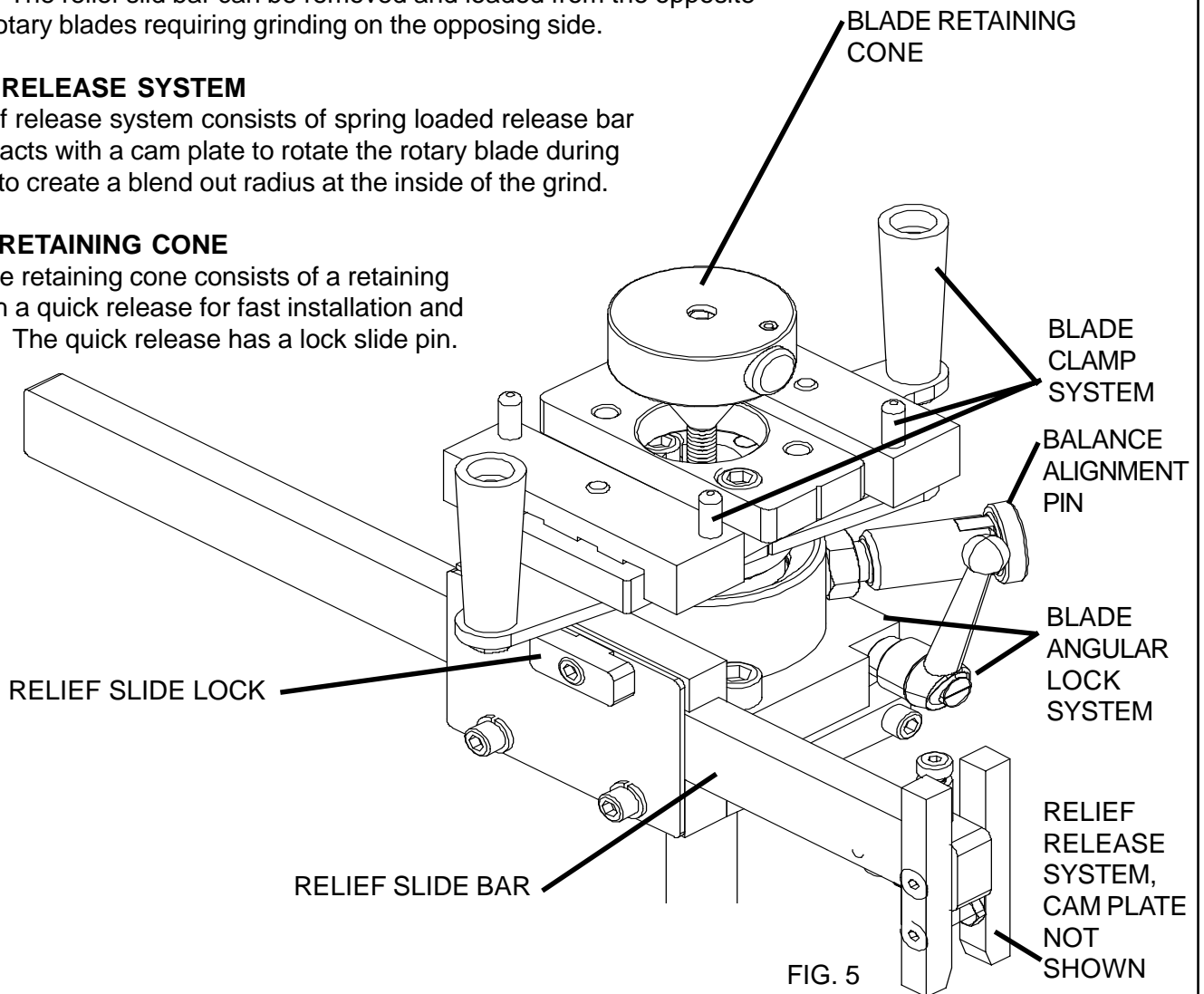

FIG. 5

GETTING TO KNOW YOUR GRINDER (Continued)

BLADE RELEASE CAM PLATE

The Blade Relief Cam Plate mounts to the carriage base plate on one or the other pins, depending on if the lower grinding head is positioned to the left or right of center. The cam plate can be removed to change pins by removing the hairpin and extension spring, and flipping the cam plate. Then reinstall the spring and hairpin.

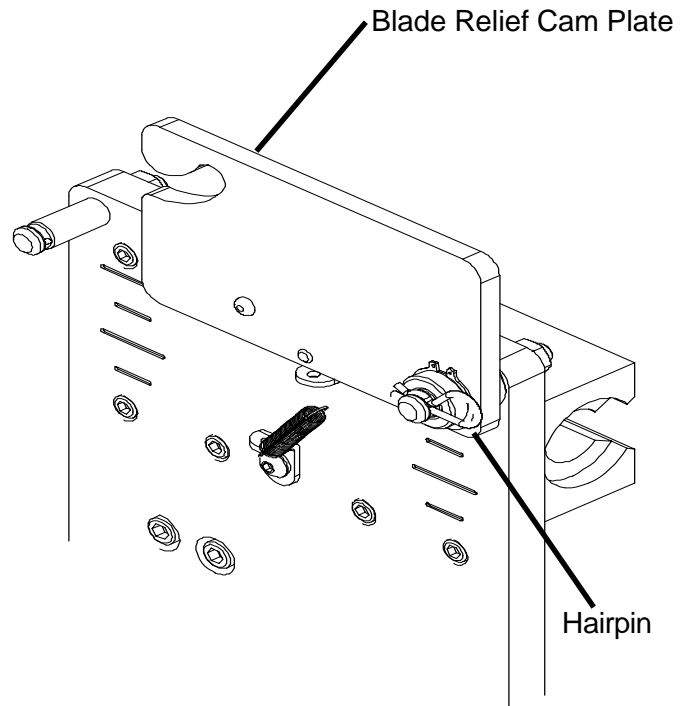

FIG. 6

TRAVERSE TRAVEL LIMIT PROXIMITY SWITCHES

The 460 Rotary Blade Grinder has proximity switches to stop the carriage travel and reverse direction. See FIG. 7. They are adjustable by loosening the star knob and sliding the assembly along the rail and retightening.

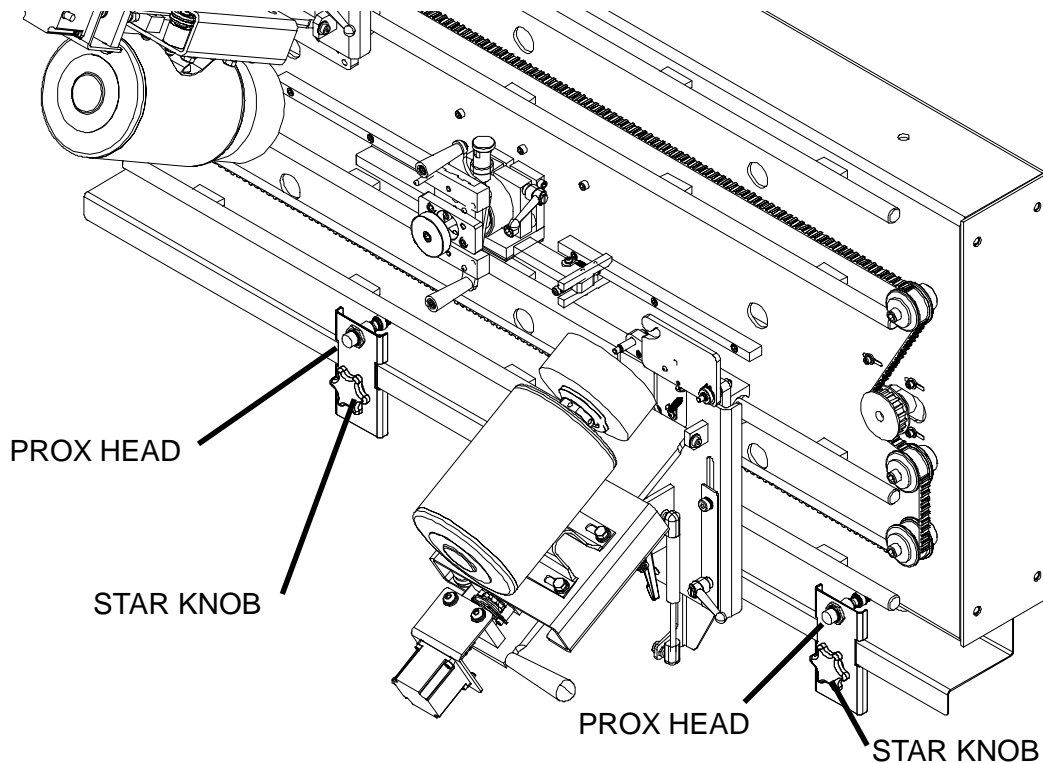

FIG. 7

GENERAL OPERATING INFORMATION (continued)

WHEN TO SHARPEN A ROTARY BLADE

When the grass is not being cut cleanly, or the cut ends of the grass appear torn or ragged, the edges of the rotary blade have become rounded and need sharpening. See FIG. 8. The purpose of sharpening is to restore the sharp edge. See FIG. 9.

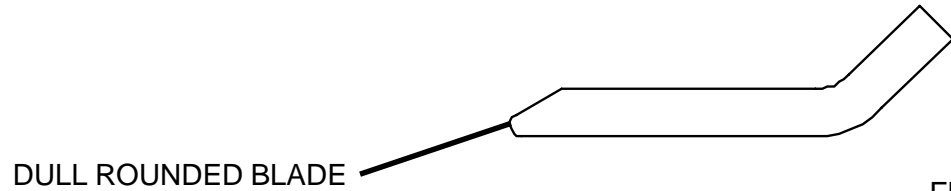

FIG. 8

ROTARY BLADE GRINDING ANGLE

The rotary blade has one face that normally needs to be ground.

The proper grinding angle for the face will vary, depending on the manufacturer. **Always follow the manufacturer's recommended specifications for rotary blade angle.**

Typically, however, there will be a 30 ± 10 degrees angle ground on the rotary blade. See FIG. 9.

How to obtain these angles is discussed in more detail in the operating instructions, beginning on Page 16.

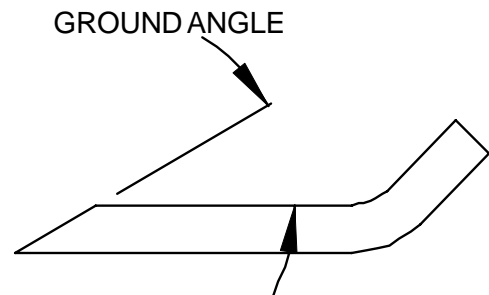

FIG. 9

GENERAL OPERATING INFORMATION (Continued)

MOUNTING A GRINDING WHEEL

To replace the grinding wheel: See FIG. 10.

1. Turn the GRINDING WHEEL switch **OFF**.
2. Open the doors.
3. Unscrew the mounting flange that holds the grinding wheel, using the special wrench provided with the grinder.
4. Remove the old wheel and install the new one.
5. Screw on the flange finger tight, then tighten approximately 1/8 turn further with the wrench. It will self-tighten when the motor is turned on.



IF THE WHEEL FLANGE IS OVERTIGHTENED, THE GRINDING WHEEL MAY CRACK AND FLY APART.

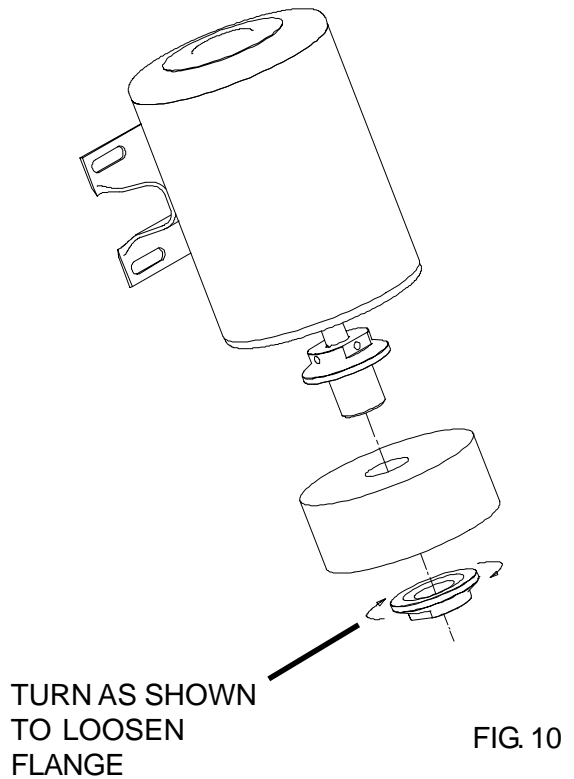

REPLACING THE WHEEL

A new grinding wheel is 2" [51 mm] deep. When it wears down to a depth of 1.0" [25 mm], it should be replaced. See FIG. 11.

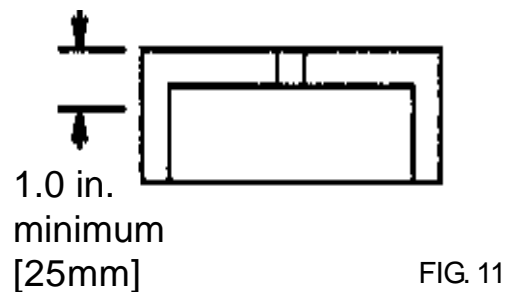

GRINDING WHEELS AVAILABLE FOR 460 ROTARY BLADE GRINDER

WHEEL PART NO.	COLOR/DESCRIPTION/SIZE	GRIT
3700046	Blue straight-cup wheel, 5 x 2 x 1.252 inch bore, ceramic	36

GENERAL OPERATING INFORMATION (Continued)

PREPARING THE ROTARY BLADE FOR SHARPENING

1. CLEANING

A rotary mower blade which has a buildup of dirt and dried grass clippings cannot be properly sharpened or balanced.

To clean your blade follow these steps:

1. Put on safety glasses.
2. Scrape off the heavy grass buildup with a flat scraper.
3. Use a wire wheel on a bench grinder or a wire brush by hand to finish cleaning.

2. INSPECT THE BLADE

If the blade is bent, twisted, or cracked, it must be replaced. See FIG. 12.



DO NOT ATTEMPT TO STRAIGHTEN OR REPAIR A BENT, CRACKED, OR TWISTED BLADE. THE USE OF SUCH A BLADE COULD PRESENT A SERIOUS SAFETY RISK.

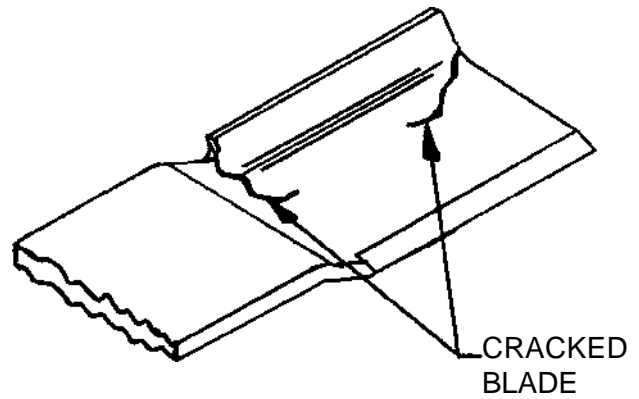

FIG. 12

OPERATING INSTRUCTIONS

MOUNTING THE ROTARY BLADE

To install the rotary blade the center cone must be removed. Rotate the blade clamp cam system counterclockwise to open the clamp blocks. Put the center hole of the rotary blade on the center threaded stud and install the center cone. To use the center cone, have the center cone lock in the unlock position, push the release button and slide the center cone so it engages the rotary blade center hole and release the button. Slide the center cone lock pin to the lock position. Then rotate the center cone to snug (not tighten) the cone to the rotary blade, Rotate the blade clamp cam system clockwise to firmly bring the pins in contact with the rotary blade. Now tighten the center cone. See FIG. 13.

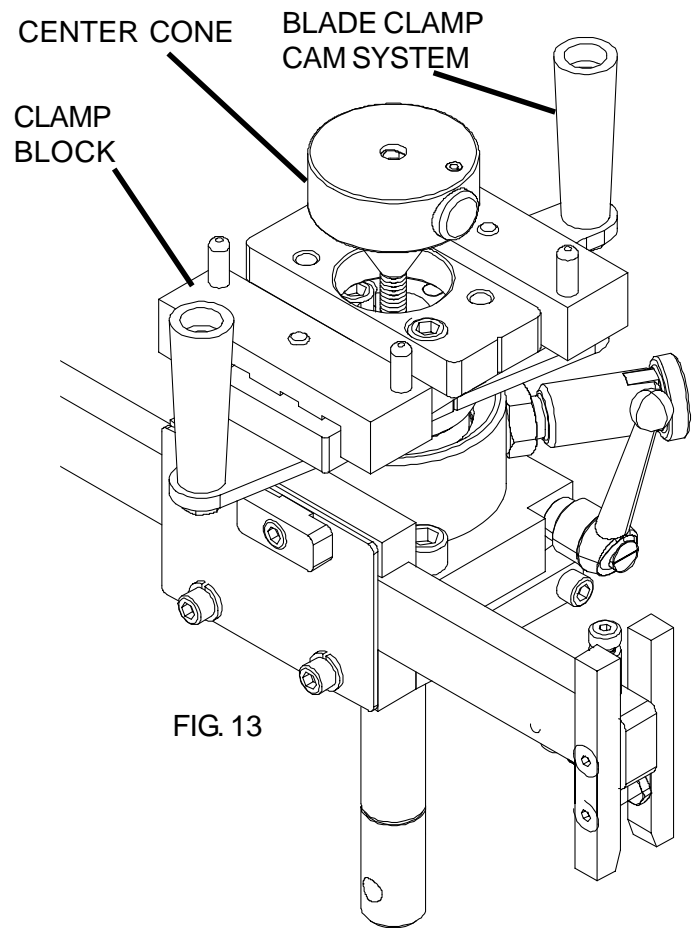

FIG. 13

DETERMINE GRINDING HEADS POSITION

After the rotary blade is mounted, look at the blade and determine if the surface to be ground on the bottom side of the rotary blade is on the left side of the blade or the right side of the blade. The majority of the blades are on the right side of the blade.

If the right side requires grinding then the lower grinding head is on the right and top upper grinding head is on the left as shown in FIG. 14.

If the left side requires grinding then the lower grinding head is on the left and top upper grinding head is on the right as shown in FIG. 15.

To move the grinding head to the opposing side it will be necessary to:

1. Remove the relief slide bar. See FIG. 5..
2. Remove the blade relief cam plate and the spring. See FIG. 6.
3. Outfeed the grinding wheels to the full back position.
4. Set the grind angle on both grinding heads to 20°.

Move the head to the opposite side and reassemble the above parts with the relief slide bar in the opposite direction and the blade relief cam plate on the opposite pin.

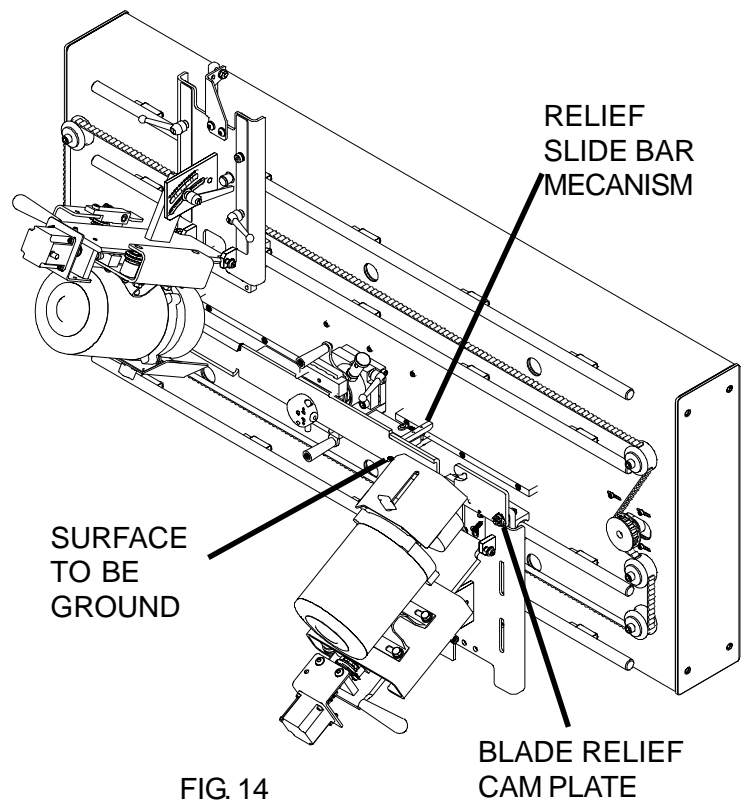

FIG. 14

OPERATING INSTRUCTIONS (Continued)

SETTING THE GRIND ANGLE

The grinding heads of this grinder have an angular adjustment to set the grind angle on the rotary blade. To set the angle, while holding the grind angle position assist handle, release the grind angle position adjuster lock handle and reposition the grind angle by pivoting the head. See FIG. 16. The repositioning system has a ball detent that drops into each hole on the angle setting adjacent to the decal mark. See FIG. 17. When your angle is correct, retighten the grind angle position adjuster lock handle.

NOTE: Each detent hole is 2° apart. Most rotary blades are ground to 30°. Some manufacturers specify an alternative angle, but all are within the 20° to 40° range that the grinder is capable. If the recommended grind is an odd number angle (25°), position the head to the closest angle, in this example 24°.

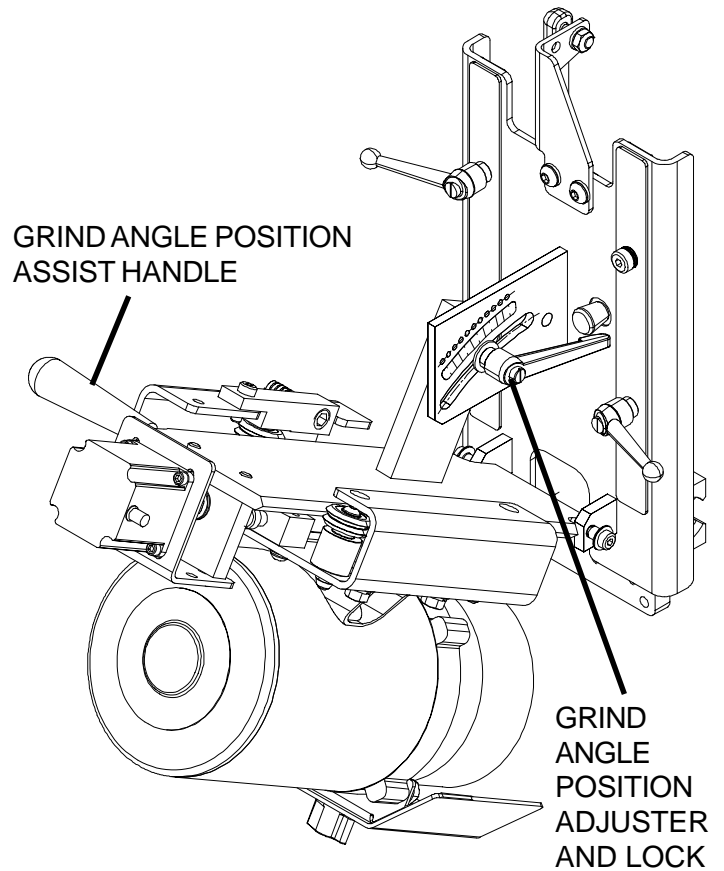

FIG. 16

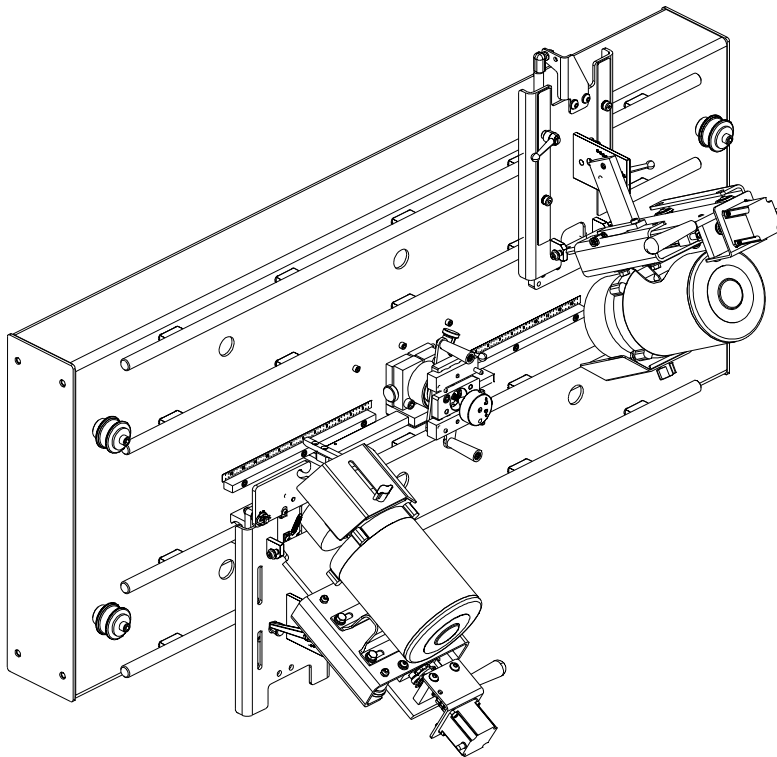

FIG. 15

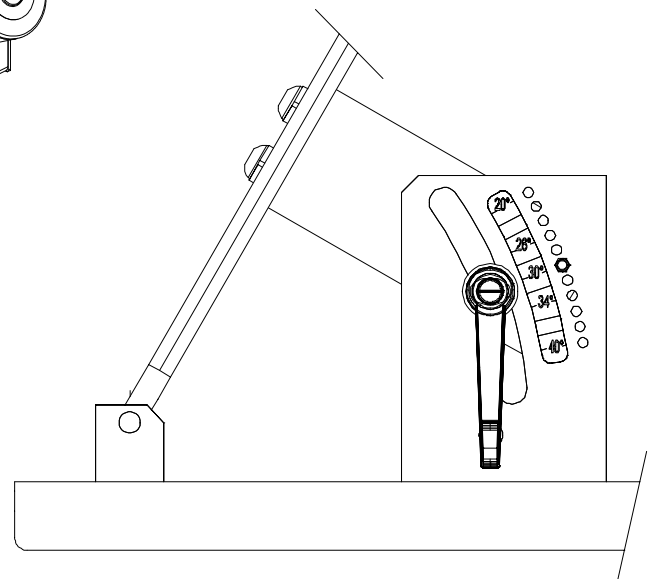

FIG. 17

OPERATING INSTRUCTIONS (Continued)

POSITIONING THE ROTARY BLADE FOR ANGLED GRINDING

If your rotary blade is flat and the cutting surface is parallel to the blade, you will not have to rotate the rotary blade. You can leave the blade angle zero position pin in place (See FIG. 18) and proceed to page 19.

If your rotary blade came from the factory with the cutting surface at an angle to the blade (See FIG. 19), or if your rotary blade has the end bent down in relation to the flat bottom mounting surface (See FIG. 20), you will need to rotate the center hub of the grinder, rotating the blade in relation to the grinding head.

To rotate the center hub and rotary blade, pull out the blade angle zero position pin and rotate 90° to lock it out. (See FIG. 18). Then loosen the blade angle lock handle and rotate the blade until the face to be ground is parallel to the grinding wheel face. See FIG. 21. This may require a grinding head vertical adjustment.

The grinding head vertical adjustment is explained on page 19.

The best method to get the angle correct is to look down from the top of the lower grinding wheel and move the blade to match the grinding wheel face and the rotary blade face to be ground.

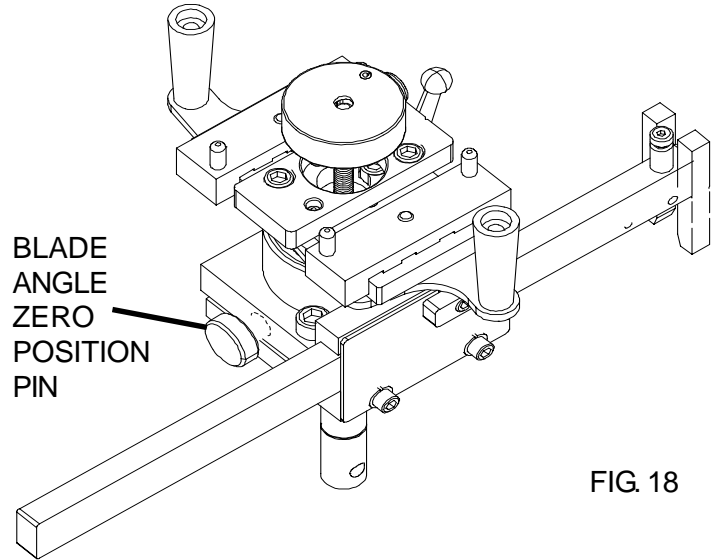

FIG. 18



FIG. 19



FIG. 20

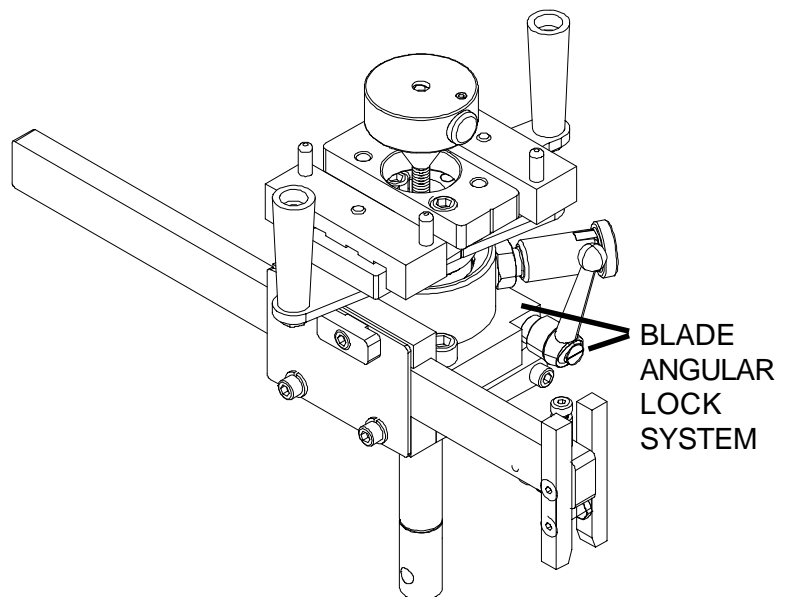

FIG. 21

OPERATING INSTRUCTIONS (Continued)

VERTICAL GRINDING HEAD ADJUSTMENT

Based on the rotary blade size or the rotation of the blade as discussed on page 18, the grinding heads may require vertical adjustment. To adjust the vertical height of the grinding heads, loosen one of the lock handles on a grinding head assembly. See FIG. 22. Then pull the vertical position lock pin and rotate 90°. Grasp the motor body near the spark guard and while supporting the weight of the motor, loosen the second lock handle and raise or lower the grinding head.



IF THE GRINDING MOTOR HAS BEEN RECENTLY RUN IT COULD BE VERY HOT. USE GLOVES TO GRASP THE MOTOR IF HOT.

When you have the motor in the vertical position required, turn the vertical position lock pin 90° and let it move in on its spring. You may need to move the grinding head up or down slightly to engage the pin. When the pin is engaged, tighten the two lock handles.

Observe the calibration marks on the carriage base plate where they meet the adjustable base plate. See FIG. 23.

Adjust the second grinding head to the same vertical position as the first using the calibration marks as your guide.

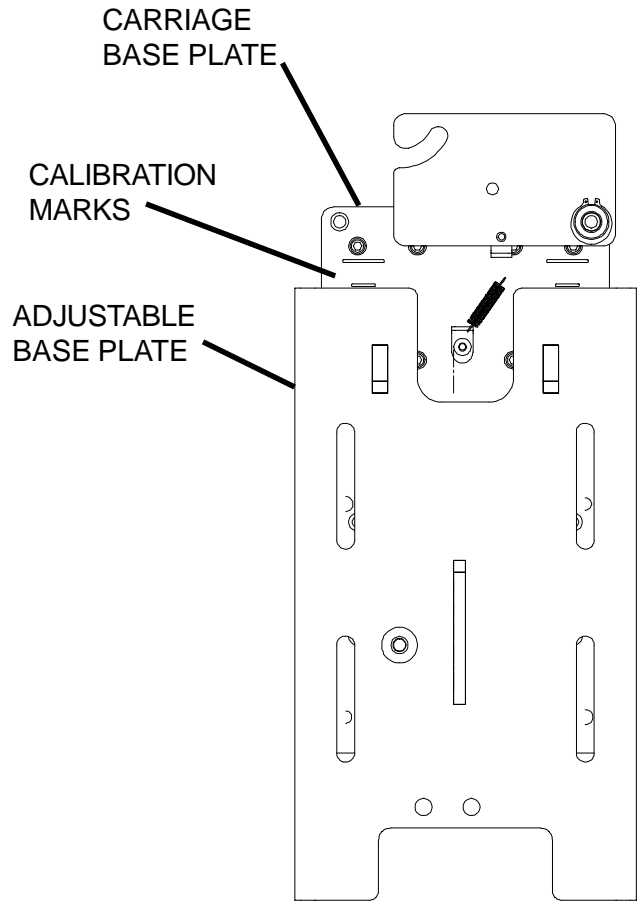

FIG. 23

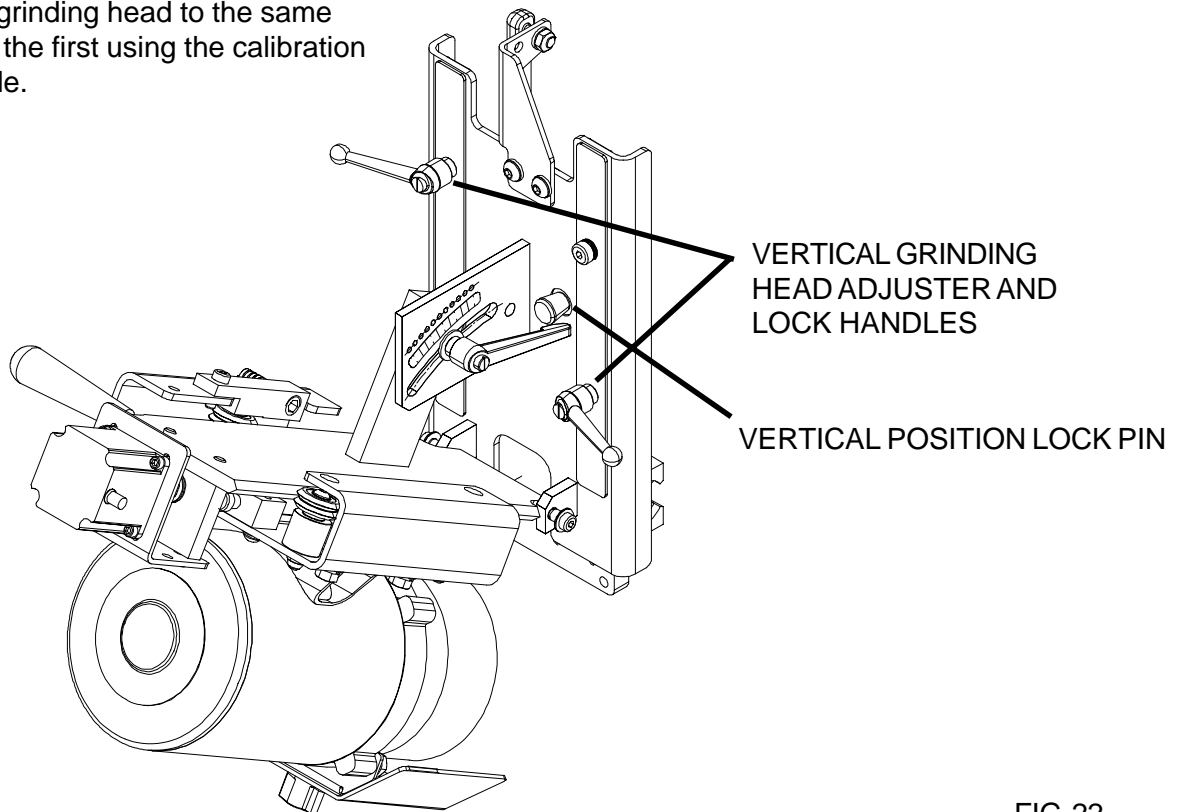

FIG. 22

OPERATING INSTRUCTIONS (Continued)

SETTING THE RELIEF RELEASE SYSTEM

The relief release system consists of a release side bar and a blade relief cam plate.

This system can be mounted with the lower grinding head on the right for rotary blades that have the surface to be ground on the right lower side when mounted. In this configuration, the relief slide bar mechanism is mounted to the right and the blade relief cam plate on the right side pin on the lower grinding head carriage. See FIG. 24.

This system can be mounted with the lower grinding head on the left for rotary blades that have the surface to be ground on the left lower side when mounted. In this configuration, the relief slide bar mechanism is mounted to the left and the blade relief cam plate on the left side pin on the lower grinding head carriage. See FIG. 25.

To set the position of the relief slide bar mechanism, measure the distance from the centerline of the rotary blade mounting hole to the manufacturers relief blend on the rotary blade. See FIG. 26.



FIG. 26

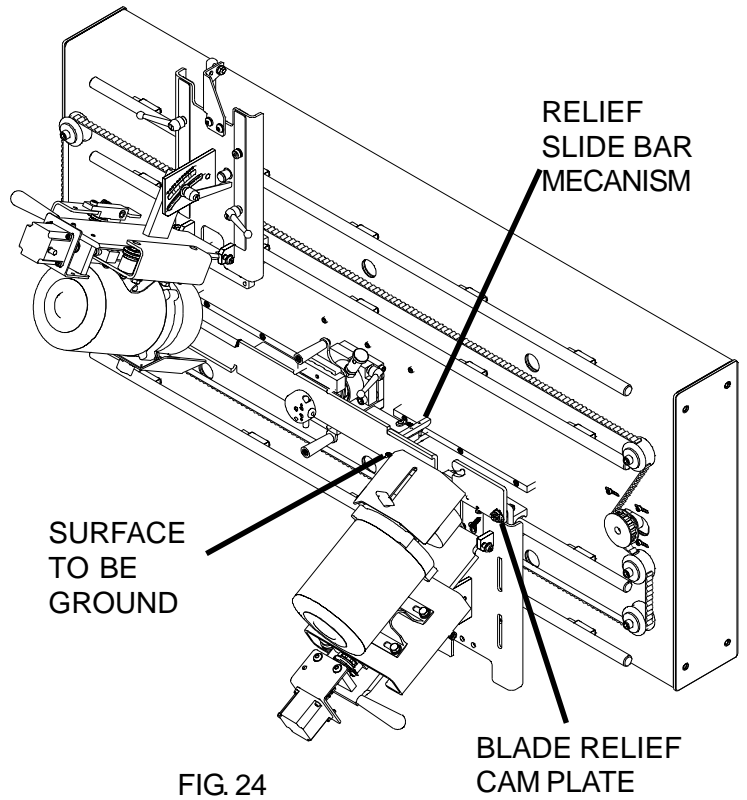

FIG. 24

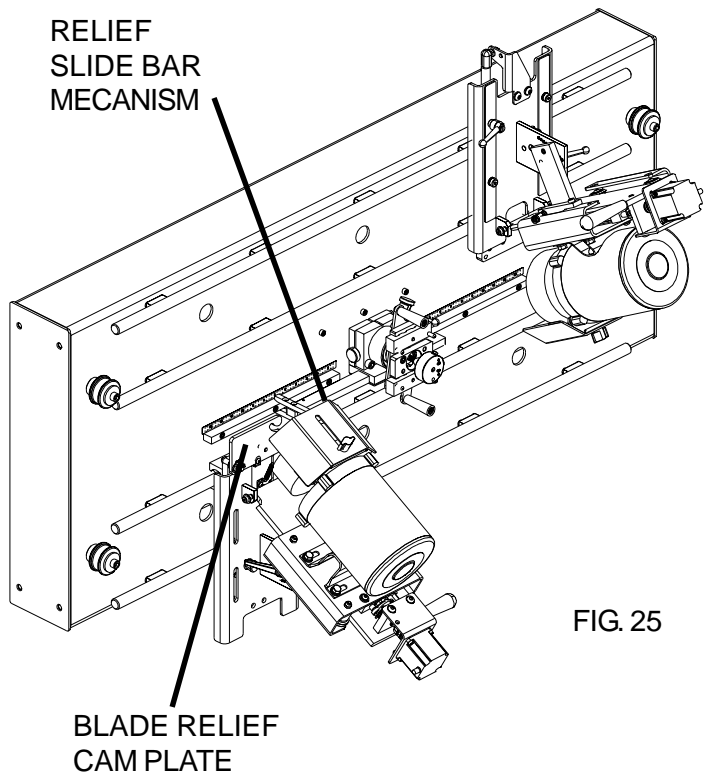

FIG. 25

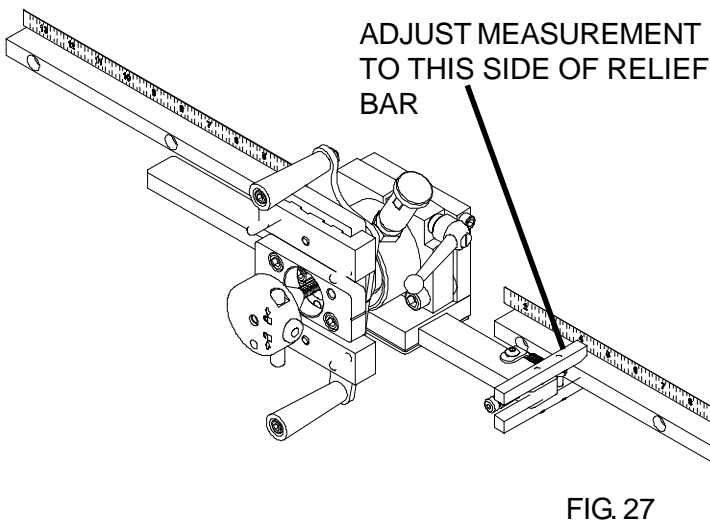

FIG. 27

OPERATING INSTRUCTIONS (Continued)

Loosen the relief slide lock knob and slide the relief bar until the side of the release bar toward the center of the grinder is at that dimension on the scale on the grinder base. See FIG. 27. When set, retighten the relief slide lock knob. This adjustment will get you very close to the correct position for the relief release system. Final adjustment will require the grinding of the blade and observing the relief cam out process. If the cam out is too early or too late, minor adjustment to the relief slide bar will be required.

When the correct position of the relief slide bar is established for a given rotary blade type, the scale dimension should be recorded on the **ROTARY BLADE SETUP CHART** at the back of this manual.

SETTING THE TRAVERSE PROXIMITY SWITCHES

With the lower grinding head on the right, the left hand traverse proximity switch must be adjusted so the relief release system travels through its full relief cycle. Therefore, manually run the traverse to the left slowly and observe the grinder traveling, engaging the relief release system and coming out. When the cam out is complete, stop the traverse by turning the traverse speed knob to zero and adjusting the left hand proximity switch by loosening the star knob and moving the switch until it just lights. Then tighten the star knob. See FIG. 28.

Now manually jog the traverse to the right until the grinding wheel comes off the rotary blade by approximately .50" [12 mm]. Again, loosen the star knob, move the right hand proximity switch until the light just lights and retighten the star knob. See FIG. 29.

When the lower grinding head is on the left, the procedure is generally the same, but the right side traverse proximity switch is aligned to the relief release system and the left side traverse proximity switch is set off the rotary blade end.

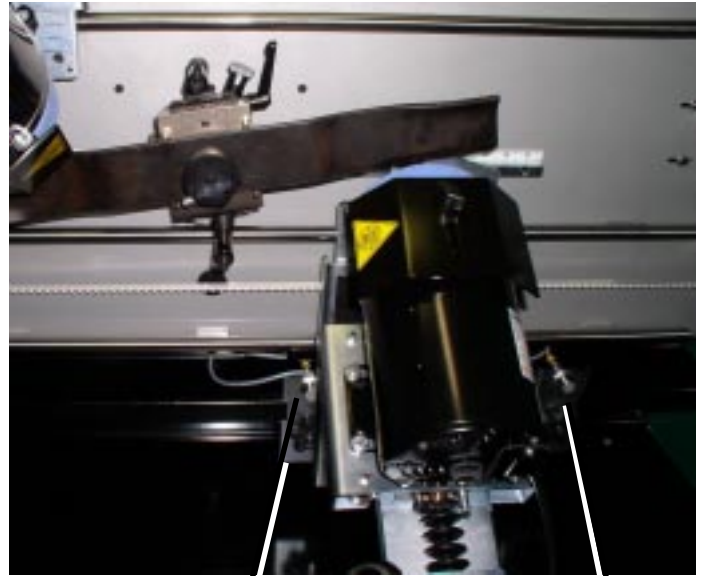

LEFT PROX SWITCH

RIGHT PROX SWITCH

FIG. 28

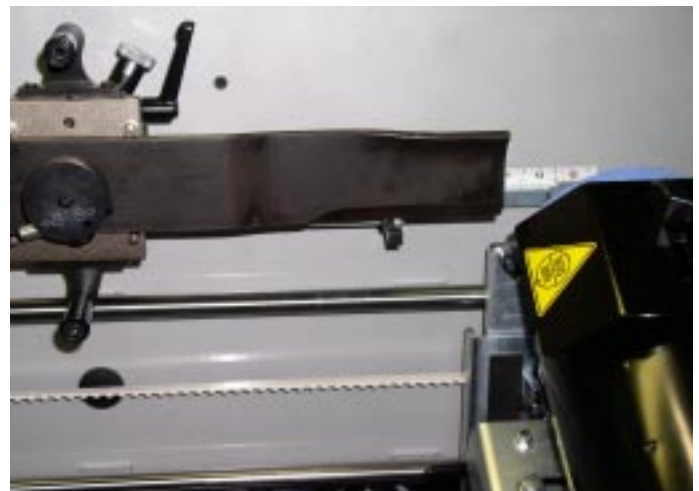

FIG. 29

OPERATING INSTRUCTIONS (Continued)

GRINDING THE ROTARY BLADE

In proceeding with the grind instructions, it is assumed that all the adjustments listed on pages 16 through 21 have been completed.

Manually jog the grinding head so the side of the grinding wheel toward the center of the grinder is approximately in the center of the blade area to be ground as shown in FIG. 30.

With the doors open, put the infeed motor selector switch in the lower motor position and jog the grinding wheel in to lightly contact the blade while manually turning the wheel. Then back off slightly. Repeat the same sequence for the upper grinding wheel with the infeed motor selector switch in the upper motor position.

Now manually run the traverse to the outside traverse proximity switch position. Then slowly run the traverse to the inside traverse proximity switch watching for clearances to the airfoil lift at the back of the rotary blade and the proper travel of the relief release system. Minor adjustments to the relief release system may be required at this time.

When the clearance checks are acceptable, close the doors to engage the door interlock switch. Again jog the grinding wheels so the inside edge of the wheel is approximately in the center of the surface to be ground. Put the infeed motor selector switch to the center (both motors) position. Turn on the grinding motors and jog in with the infeed speed selector switch in the turtle position until light contact is made with the grinding wheel. If both wheels do not make contact at the same time, move the infeed motor selector switch to the side of the trailing grinding wheel and jog that grinding wheel in until the two grinding wheels have a uniform touch to the rotary blade.

Jog to the outside traverse proximity switch and you are ready to automatically grind the rotary blade.

Each time you push the automatic program start button you will infeed .010" [.25 mm]. This is accomplished by infeeding .002" [.05 mm] and traversing in and out one pass. This is repeated 5 times to infeed the .010" [.25 mm]. Therefore, if you want to grind off approximately .010" [.25 mm] push the button once. If you want to remove approximately .040" [1.0 mm] push the button 4 times or if you want to remove approximately .070" [1.75 mm] push the button 7 times.

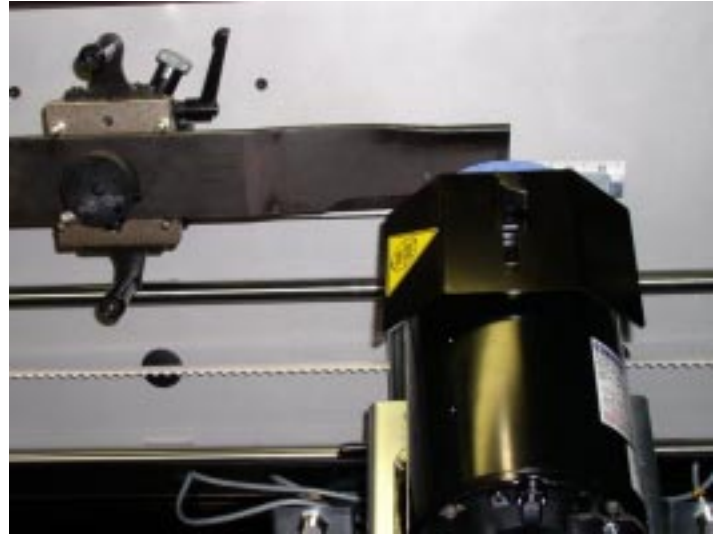

FIG. 30

OPERATING INSTRUCTIONS (Continued)

The grinder has been engineered with a three second time delay. If you do not push the button for three seconds, the automatic program will start and grind the rotary blade based on the number of times you pushed the button prior to the three second time delay.

When running the automatic cycle, if you determine the grind is too heavy or too light, you can jog the infeed or "outfeed" during the automatic cycle to adjust the grind.

When the grind sequence is completed, the grinder will return to the outside traverse proximity switch and shut off all functions. At this time the doors can be opened and the rotary blade inspected. If the sharpening is complete, move on to balancing the blade as described below. If not close the doors and push the automatic program start button as required to grind additional stock from the rotary blade until sharp.

During the automatic grind program, if you want to stop the automatic cycle for any reason, push the automatic program start button. The grinder will complete the traverse pass it is on and when it hits the outside proximity switch it will stop the automatic cycle it was running.

BALANCING THE ROTARY BLADE

When the rotary blade is sharp, to balance the blade, pull out and turn 90° the balancer lock pin. See FIG. 31. This will allow the center support assembly and rotary blade to freely rotate.

The heavy side of the blade will rotate to the bottom of the grinder. Once you determine the heavy side, rotate the blade back into position and reengage the balancer lock pin.

Turn the infeed motor selector switch to the grinding wheel on the side of the blade that is heavy. Close the doors and push the automatic program start button, again taking off .010" [.25 mm] per push. Because you have put the infeed motor selector switch to the heavy side all the grinding should occur on that side. **NOTE:** Some grinding may occur on the light side, but this should diminish or stop after a traverse pass or two.

At the end of this automatic cycle, recheck the blade balance. If good, proceed to the next blade to be ground. If more stock must be removed to achieve balance, close the doors and again push the automatic program start button as required.

NOTE: If the next rotary blade is the same size and type as the last, no or minimal setup should be required and you should be able to go into automatic cycle quickly.

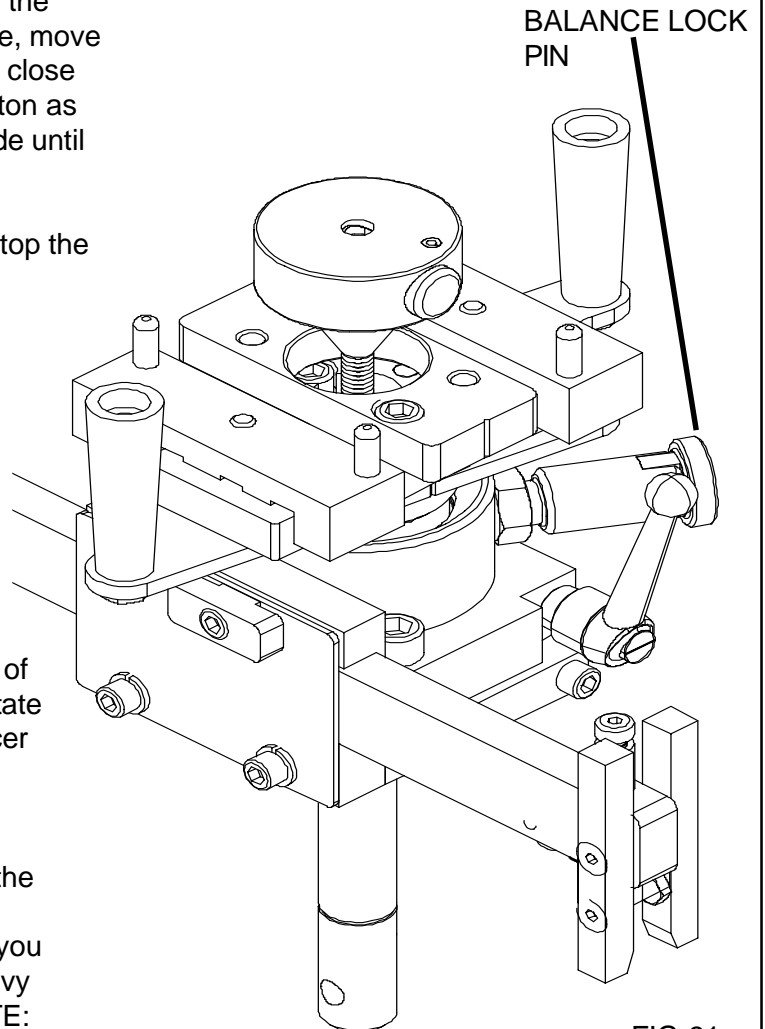

FIG. 31



WHEN THE ROTARY BLADE SHARPENING PROCESS IS COMPLETED THE BLADE IS EXTREMELY SHARP AND HOT. IT MUST BE HANDLED WITH CAUTION TO AVOID PERSONAL INJURY.

ROTARY BLADE STUP CHART

ROTARY BLADE SETUP CHART

ROTARY BLADE MAKE & MODEL	RELIEF SLIDE BAR POSITION FROM SCALE	ROTARY BLADE MOUNT ANGLE	TRAVERSE SPEED SETTING	BLADE GRIND ANGLE	GR. HEAD VERTICAL POSITION	NOTES